

# Sealed Subminiature Basic Switch D2SW-P

## Sealed Basic Switch with Simplified Construction, Mounting Compatible with SS and D2SW Series.

- Sealed to IEC IP67.
- Switch rating of 2A at 250 VAC possible with a single-leaf movable spring. Models for micro loads are also available.
- Solder, quick-connect terminals (#110), PCB terminals and molded lead wires are available. Even-pitched PCB terminals are also standardized.

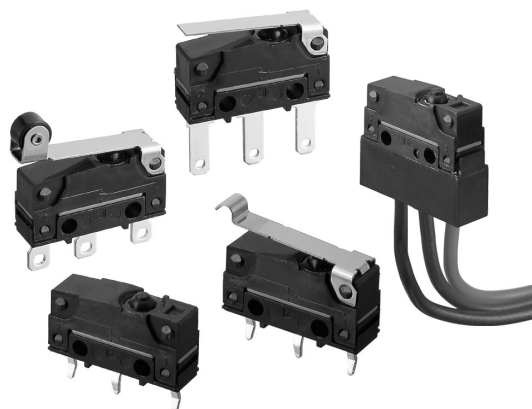

## Ordering Information

### Model Number Legend

D2SW-P 

  
1 2 3 4

#### 1. Ratings

- 2: 2A at 250 VAC
- 01: 0.1A at 30 VDC

#### 2. Actuator

- None: Pin plunger
- L1: Hinge lever
- L2: Hinge roller lever
- L3: Simulated roller lever

#### 3. Contact Form

- None: SPDT
- 2: SPST-NC (Molded lead wire models only)
- 3: SPST-NO (Molded lead wire models only)

#### 4. Terminals

- H: Solder terminals
- T: Quick-connect terminals (#110)
- D: PCB terminals (Uneven pitch)
- B: PCB terminals (Even pitch)
- M: Molded lead wires

### List of Models

Rating	Actuator	Terminal	Solder terminals	Quick-connect terminals (#110)	PCB terminals		Molded lead wires
					Uneven pitch	Even pitch	
2A	Pin plunger		D2SW-P2H	D2SW-P2T	D2SW-P2D	D2SW-P2B	D2SW-P2M
	Hinge lever		D2SW-P2L1H	D2SW-P2L1T	D2SW-P2L1D	D2SW-P2L1B	D2SW-P2L1M
	Hinge roller lever		D2SW-P2L2H	D2SW-P2L2T	D2SW-P2L2D	D2SW-P2L2B	D2SW-P2L2M
	Simulated roller lever		D2SW-P2L3H	D2SW-P2L3T	D2SW-P2L3D	D2SW-P2L3B	D2SW-P2L3M
0.1A	Pin plunger		D2SW-P01H	D2SW-P01T	D2SW-P01D	D2SW-P01B	D2SW-P01M
	Hinge lever		D2SW-P01L1H	D2SW-P01L1T	D2SW-P01L1D	D2SW-P01L1B	D2SW-P01L1M
	Hinge roller lever		D2SW-P01L2H	D2SW-P01L2T	D2SW-P01L2D	D2SW-P01L2B	D2SW-P01L2M
	Simulated roller lever		D2SW-P01L3H	D2SW-P01L3T	D2SW-P01L3D	D2SW-P01L3B	D2SW-P01L3M

**Note:** Consult your OMRON sales representative for details on SPST-NO and SPST-NC models.

# Specifications

## ■ Ratings

Model	Rated voltage	Resistive load
D2SW-P2	30 VDC	2 A
	250 VAC	
D2SW-P01	30 VDC	0.1 A
	125 VAC	

**Note:** The ratings values apply under the following test conditions.  
 Ambient temperature: 20±2°C  
 Ambient humidity: 65±5%  
 Operating frequency: 20 operations/min.

## ■ Characteristics

Item	Model	
	D2SW-P2	D2SW-P01
<b>Operating speed</b>	0.1 mm to 500 mm/s (pin plunger models)	
<b>Operating frequency</b>	Mechanical: 120 operations/min max. Electrical: 20 operations/min max.	
<b>Insulation resistance</b>	100 MΩ min. (at 500 VDC)	
<b>Contact resistance (initial value)</b>	Terminal models: 50 mΩ max. Molded lead wire models: 100 mΩ max.	Terminal models: 100 mΩ max. Molded lead wire models: 150 mΩ max.
<b>Dielectric strength (see note 2)</b>	1,000 VAC, 50/60 Hz for 1 min. between terminals of the same polarities	600 VAC, 50/60 Hz for 1 min. between terminals of the same polarities
	1,500 VAC, 50/60 Hz for 1 min. between current-carrying metal parts and ground, and between each terminal and non-current-carrying metal parts	
<b>Vibration resistance (see note 3)</b>	Malfunction: 10 to 55 Hz, 1.5-mm double amplitude	
<b>Shock resistance (see note 3)</b>	Destruction: 1,000 m/s <sup>2</sup> {approx. 100 G} max. Malfunction: 300 m/s <sup>2</sup> {approx. 30 G} max.	
<b>Durability (see note 4)</b>	Mechanical: 1,000,000 operations min. (60 operations/min.) Electrical: 50,000 operations min. (20 operations/min.)	Mechanical: 1,000,000 operations min. (60 operations/min.) Electrical: 200,000 operations min. (20 operations/min.)
<b>Degree of protection</b>	IEC IP67 (see note 5) (excluding the terminals on terminal models)	
<b>Degree of protection against electric shock</b>	Class 1	
<b>Proof tracking index (PTI)</b>	175	
<b>Ambient operating temperature</b>	-20°C to 70°C (at ambient humidity of 60% max.) (with no icing)	
<b>Ambient operating humidity</b>	85% max. (for 5°C to 35°C)	
<b>Weight</b>	Approx. 2 g (pin plunger models with terminals)	

- Note:**
- The data given above are initial values.
  - The dielectric strength shown in the table indicates a value for models with a Separator.
  - For the pin plunger models, the above values apply for both the free position and total travel position. For the lever models, the values apply at the total travel position. Contact opening or closing time is within 1ms.
  - Consult your OMRON sales representative for testing conditions.
  - The test to meet standards checks for water intrusion after immersion for 30 minutes. The test does not check for switching operation underwater. Refer to “**Degree of Protection**” or “**Instructions for Correct Use**”.

## Approved Standards

Consult your OMRON sales representative for specific models with standard approval.

**UL1054 (File No. E41515)/  
CSA C22.2 No. 55 (UL approval)**

Rated voltage	D2SW-P2	D2SW-P01
125 VAC	—	0.1 A
250 VAC	2 A	—
30 VDC	2 A	0.1 A

## Contact Specifications

Item		Model	
		D2SW-P2	D2SW-P01
Contact	Specification	Rivet	Crossbar
	Material	Silver alloy	Gold alloy
	Gap (standard value)	0.5 mm	
Minimum applicable load (see note)		160 mA at 5 VDC	1 mA at 5 VDC

**Note:** For more information on the minimum applicable load, refer to *Using Micro Loads* on page 6.

## Dimensions

### Terminals

- Note: 1.** All units are in millimeters unless otherwise indicated.
- 2.** Terminal plate thickness is 0.5 mm for all models.

#### Solder Terminals

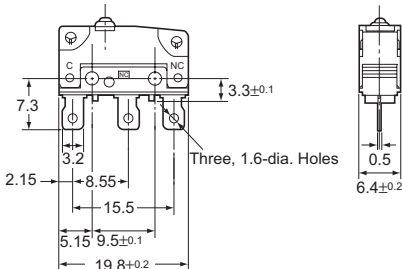

#### PCB Terminals (Uneven pitch)

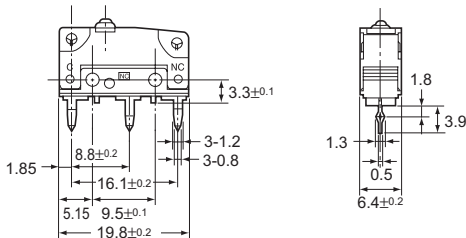

#### PCB Mounting Dimensions (Reference)

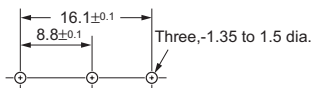

## Contact Form

### SPDT

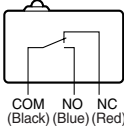

### SPST-NC (Molded lead wire models only)

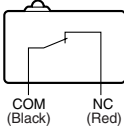

### SPST-NO (Molded lead wire models only)

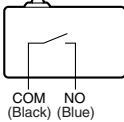

**Note:** Lead wire colors are indicated in parentheses.

#### Quick-connect Terminals (#110)

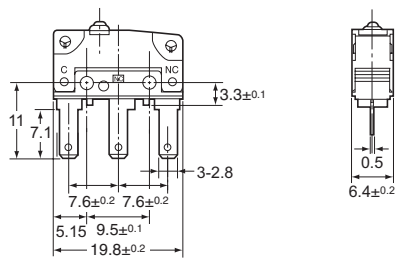

#### PCB Terminals (Even pitch)

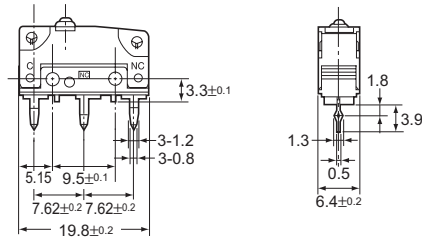

#### PCB Mounting Dimensions (Reference)

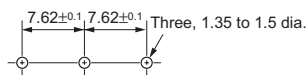

**Molded Lead Wires**

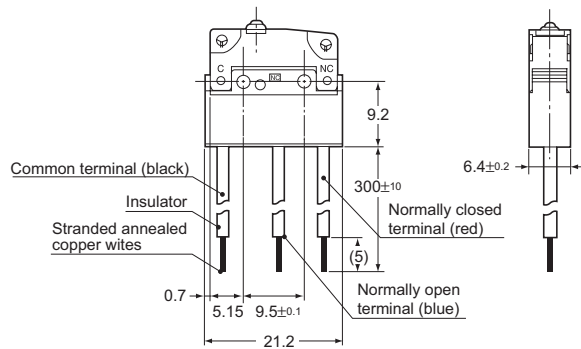

**■ Mounting Holes**

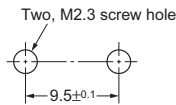

**■ Dimensions and Operating Characteristics**

**Note:** 1. All units are in millimeters unless otherwise indicated.

2. The following illustrations and drawings are for solder terminal models. Refer to *Terminals* section for details on models with quick-connect terminals (#110) or PCB terminals or molded lead wires.
3. The □ in the model number is for the contact form code or the terminal code.
4. Unless otherwise specified, a tolerance of ±0.4 mm applies to all dimensions.
5. The operating characteristics are for operation in the A direction (↓).

**Pin Plunger Models**

D2SW-P2□□  
D2SW-P01□□

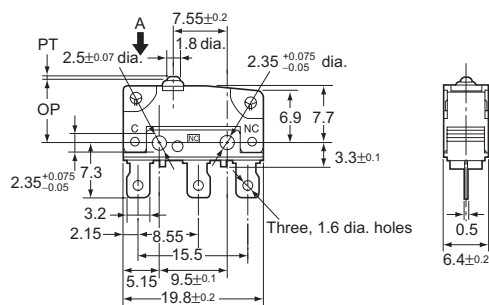
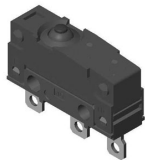

Model	D2SW-P2□□	D2SW-P01□□
OF max.	1.8 N {183 gf}	
RF min.	0.2 N {20 gf}	
PT max.	0.6 mm	
OT min.	0.4 mm	
MD max.	0.15 mm	
OP	8.4±0.3 mm	

**Hinge Lever Models**

D2SW-P2L1□□  
D2SW-P01L1□□

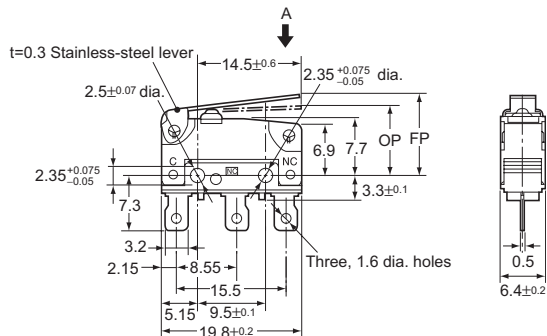
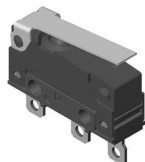

Model	D2SW-P2L1□□	D2SW-P01L1□□
OF max.	0.6 N {61 gf}	
RF min.	0.05 N {5 gf}	
OT min.	0.8 mm	
MD max.	0.8 mm	
FP max.	13.6 mm	
OP	8.8±0.8 mm	

### Hinge Roller Lever Models

D2SW-P2L2□□  
D2SW-P01L2□□

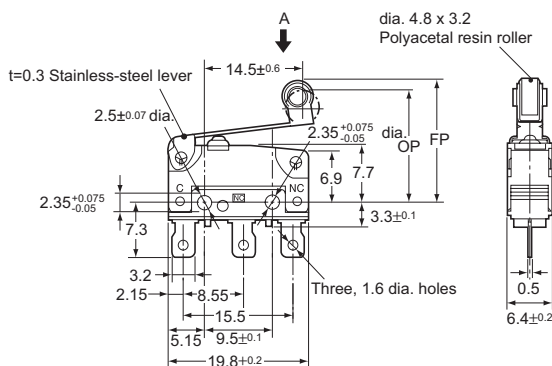
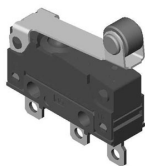

Model	D2SW-P2L2□□	D2SW-P01L2□□
OF max.	0.6 N {61 gf}	
RF min.	0.05 N {5 gf}	
OT min.	0.8 mm	
MD max.	0.8 mm	
FP max.	19.3 mm	
OP	14.5±0.8 mm	

### Simulated Roller Lever Models

D2SW-P2L3□□  
D2SW-P01L3□□

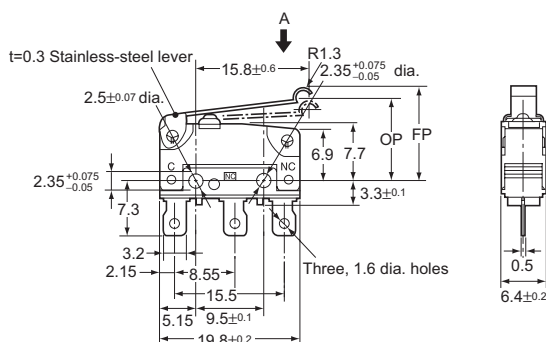
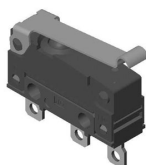

Model	D2SW-P2L3□□	D2SW-P01L3□□
OF max.	0.6 N {61 gf}	
RF min.	0.05 N {5 gf}	
OT min.	0.8 mm	
MD max.	0.8 mm	
FP max.	15.5 mm	
OP	10.7±0.8 mm	

## Precautions

### ■ Cautions

#### Degree of Protection

Do not use this product in water. Although these models satisfy the test conditions for the standard given below, this test is to check the ingress of water into the switch enclosure after submerging the Switch in water for a given time. Satisfying this test condition does not mean that the Switch can be used in water.

IEC 60529: 2001 Degrees of protection provided by enclosures (IP Code)

Code: IP67 (The test to meet the standard checks for water intrusion after immersion for 30 minutes.)

Do not operate the Switch when it is exposed to water spray, or when water drops adhere to the Switch surface, or during sudden temperature changes, otherwise water may intrude into the interior of the Switch due to a suction effect.

Prevent the Switch from coming into contact with oil and chemicals. Otherwise, damage to or deterioration of Switch materials may result.

Do not use the Switch in areas where it is exposed to silicon adhesives, oil, or grease, otherwise faulty contact may result due to the generation of silicon oxide.

The environment-resistant performance of the switch differs depending on operating loads, ambient atmospheres, and installation conditions, etc. Please perform an operating test of the switch in advance under actual usage conditions.

#### Connecting to Terminals

##### Connecting to Solder Terminals

When soldering the lead wire to the terminal, first insert the lead wire conductor through the terminal hole and the conduct soldering.

Make sure that the temperature at the tip of the soldering iron is 350 to 400°C. Do not take more than 3 seconds to solder the switch terminal, and do not impose external force on the terminal for 1 min. after soldering. Improper soldering involving an excessively high temperature or excessive soldering time may deteriorate the characteristics of the Switch.

##### Connecting to Quick-connect Terminals

Wire the quick-connect terminals (#110) with receptacles. Insert the terminals straight into the receptacles. Do not impose excessive force on the terminal in the horizontal direction, otherwise the terminal may be deformed or the housing may be damaged.

##### Connecting to PCB Terminal Boards

When using automatic soldering baths, we recommend soldering at 260±5°C within 5 seconds. Make sure that the liquid surface of the solder does not flow over the edge of the board.

When soldering by hand, as a guideline, solder with a soldering iron with a tip temperature of 350 to 400°C within 3 seconds, and do not apply any external force for at least 1 minute after soldering. When applying solder, keep the solder away from the case of the Switch and do not allow solder or flux to enter the case.

#### Side-actuated (Cam/Dog) Operation

When using a cam or dog to operate the Switch, factors such as the operating speed, operating frequency, push-button indentation, and material and shape of the cam or dog will affect the durability of the Switch. Confirm performance specifications under actual operation conditions before using the Switch in applications.